



LANDSCAPE TRAILER

A C C E S S O R I E S



NOTHING WORKS LIKE A DOGG™

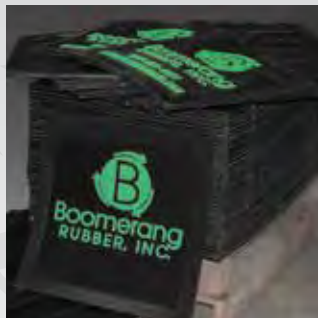

Our History



1946 Buyers Products Company founded by Sam Ruven and Bessie Kleinman as a distributor of driveline components.



Buyers continued to grow its product offerings and build valued relationships with customers and suppliers. Increased demand for products led to the pursuit of supply chain manufacturing solutions.



1992 Buyers acquired Trailer Components Manufacturing (Tracom) for CNC precision machining and tooling, as well as state-of-the-art welding.



1995 Buyers acquired Progressive Powder Coating. Our Nordson automatic powder application booth is used to powder coat our Buyers toolboxes and other truck and trailer accessories.



2002 Buyers moved its corporate headquarters to a brand new 235,000 sq. ft. state-of-the-art office and distribution center.



2004 Buyers acquired Romotech in New Paris, Indiana. Our Ferry Industries Rotospeed molding machines are used to manufacture our poly salt spreaders.



2007 Buyers began manufacturing the SnowDog stainless steel snowplow at our Mentor, Ohio facility.



2009 Buyers began our operations at Boomerang Rubber, in Botkins, Ohio manufacturing mudflaps, wheel chocks and other rubber truck and trailer accessories.



2013 Buyers acquired an additional 500,000 sq. ft. manufacturing facility in Mentor, Ohio allowing for expansion of our aluminum and stainless steel manufacturing.



2016 Buyers establishes a 22,000 sq ft Engineering Tech Center in Mentor, Ohio. It's multi-use lab, design, training and prototyping space is dedicated to the research and development of innovative product.

ALL YOUR WORK TRUCK PRODUCTS ALL THE TIME.

2017 Buyers launches new website with business partner portal, to make online ordering and account maintenance easy for customers.



2021 Buyers adds almost 300,000 sq ft of additional, state-of-the-art warehouse and office space to maintain the quick turnaround and competitive value their customers expect.

Our Corporate Family of Companies



Founded in 1946, Buyers Products is a fully integrated manufacturer and a leader in the truck equipment industry. Our engineering, manufacturing and assembly operations take place in the USA, under the Buyers family of companies. **Buyers Products' mission is to improve our Customers' profitability and productivity while enhancing the quality of our products and services.**





LANDSCAPE TRAILER ACCESSORIES

Trimmer Racks	4-5
Multi-Racks	6-7
Mounting Bracket for Round Trailer Rails	7
Blower Racks	8
Gas Container Racks	8
Water Cooler Racks	9
Traffic Cone Holders	10
Shovel Holders	11
Stake Pocket	12-13
Strip Lights	14-15
Dome Lights	16
Work Lights	17
E-Track	18-21
Conspicuity Tape	21
EZ Gate™ Tailgate Assist	22
Trailer Tongue Tool Boxes	23

NEW PRODUCTS:

4-POSITION TRIMMER RACK

pg. 4

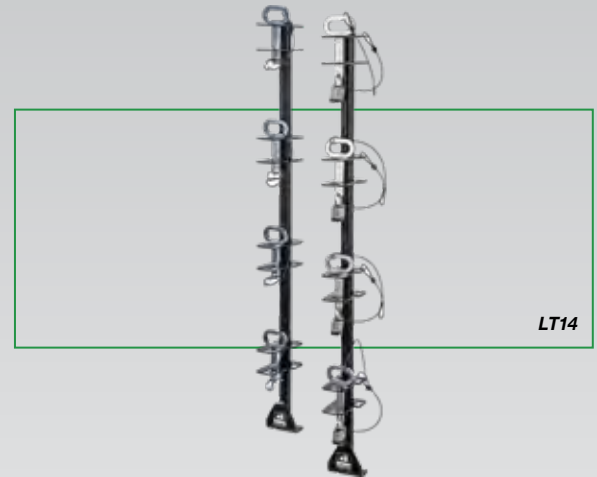

LT14

SILICONE LED STRIP LIGHTS

pg. 14



5622120

NEW Landscape Counter Mat Available

A bright, eye-catching way to let your customers see at a glance what you can do for their landscape trailer.

Ask your sales rep about how to get some for your counters!

- Part No: 3048373
- Size: 19"W x 13"H



NOTHING WORKS LIKE A DOGG

For additional landscape trailer products, visit www.buyersproducts.com



Landscape Trailer Racks

TRIMMER RACKS



LOCKING FLAT PIN

- Trimmer hooks are heavy duty, vinyl coated to protect from dings and scratches
- Hooks feature multiple flat pin slots to accommodate various trimmers and reduce rattling
- Mounting hardware and lock(s) included
- Trimmer not included



1-Position



Part No.	Description	Wt. (lb)	Cat.
LT16	1-Position Trimmer Rack	8	538(Y)



See page 7 for mounting bracket for round trailer rails.

2-Position

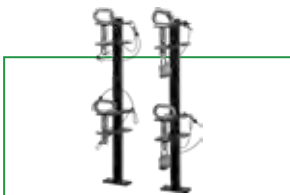

Part No.	Description	Wt. (lb)	Cat.
LT18	2-Position Trimmer Rack	13.255	538(Y)



See page 7 for mounting bracket for round trailer rails.

3-Position

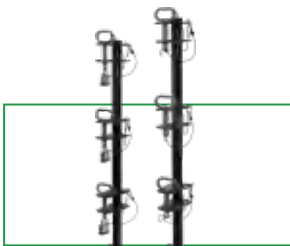

Part No.	Description	Wt. (lb)	Cat.
 LT13	3-Position Trimmer Rack	18.5	538(Y)



See page 7 for mounting bracket for round trailer rails.

4-Position

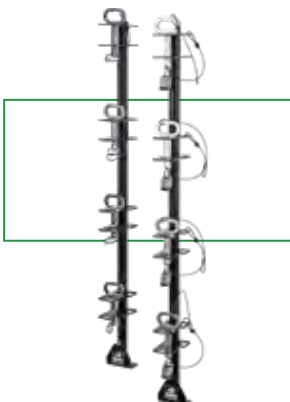

Part No.	Description	Wt. (lb)	Cat.
LT14*	4-Position Trimmer Rack	23.755	538(Y)



See page 7 for mounting bracket for round trailer rails.

* **NEW** PRODUCTS





Products are Retail Packaged

LOCKING SNAP-IN RACK, 3-POSITION

- Easy, snap-in design for effortless storage of up to 3 trimmers
- Lock bar secures 3 trimmer racks with 1 padlock
- Stainless steel springs maintain snap back even with

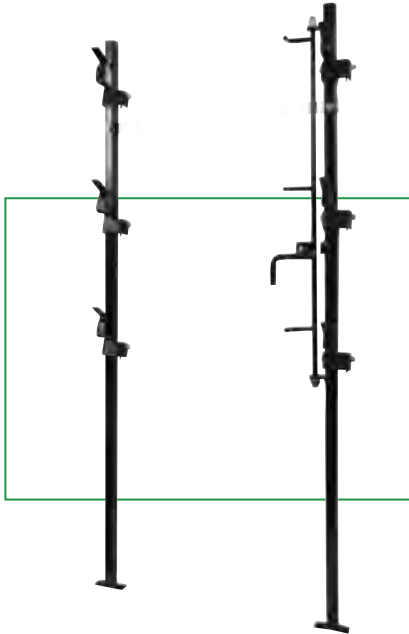
- repeated daily use
- Black powder-coated for corrosion resistance
- Padlock not included



Part No.	Description	Wt. (lb)	Cat.
 LT10	3-Position Snap-In Lockable Trimmer Rack	25	538(Y)
3004090	Replacement Lock Bar for LT10	2	538(Y)

SNAP-IN RACK, 3-POSITION

- Easy, snap-in design for effortless storage of up to 3 trimmers
- Stainless steel springs maintain snap back even with repeated daily use
- Black powder-coated for corrosion resistance

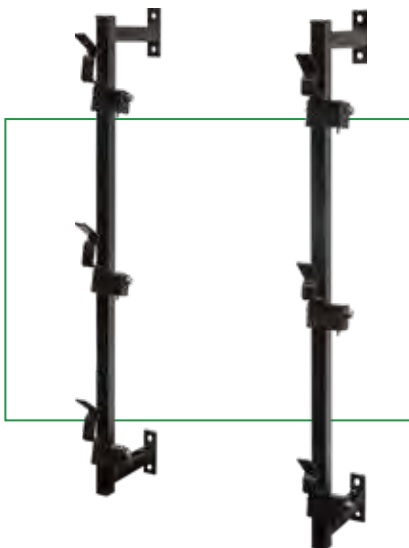

Part No.	Description	Wt. (lb)	Cat.
 LT12	Snap-In Trimmer Rack 3-Position	14.7	538(Y)



Landscape Trailer Racks

MULTI-RACKS



Storage Basket



Part No.	Description	Wt. (lb)	Cat.
LT45	Storage Basket, Multi-Purpose	105	538(Y)

Includes:

Part No.	Description	Wt. (lb)	Cat.
LT40†	Trimmer Line Spool Bracket [A]	3.1	538(Y)
LT20†	Backpack Blower Rack [B]**	7	538(Y)

**Not for use with Stihl® BR blower
†Can be purchased separately

See page 7 for mounting bracket for round trailer rails.



- Can accommodate up to 250 lbs evenly distributed
- Fits open trailers 4'10"—6'8" wide
- Includes trimmer line holder and backpack blower holder
- Includes positional dividers
- Heavy duty black powder-coated
- Includes mounting hardware
- Blower and tools not included

Hand Tool Rack – Optional Accessory



Part No.	Description	Wt. (lb)	Cat.
LT46	Hand Tool Rack	14.5	538(Y)

- Holds 5 straight, triangle or D-handle tools
- Bolts on to LT45
- Includes mounting hardware

Trimmer Line Spool Bracket



Part No.	Description	Wt. (lb)	Cat.
LT40	Trimmer Line Spool Bracket	3.1	538(Y)

- Holds one 3 lb. or 5 lb. line spool (not included)
- Powder-coated steel construction
- Mounting hardware included
- Trimmer line not included



Multi-Rack



Part No.	Description	Wt. (lb)	Cat.
LT15	Multi-Rack	19	538(Y)

- Holds chainsaw, hedge trimmers, hand blower
- Includes rubber straps to secure equipment
- Includes bracket to mount in enclosed trailer
- Includes bracket to fit hedge-trimmer
- Chainsaw not included



Multi-Rack with Lockable Lid



Part No.	Description	Wt. (lb)	Cat.
LT17	Multi-Rack with Lockable Lid	20	538(Y)

- Lid-to-base locking mechanism (lock not included)
- Includes rubber anti-vibration skid pad
- Includes bracket to fit hedge-trimmer
- Includes rubber straps and mounting hardware



Mounting Bracket for Round Trailer Rails



Part No.	Description	Wt. (lb)	Cat.
LT59	Mounting Bracket for Round Trailer Rails	1.76	538(Y)

- Clamps to round trailer rails for installation of racks
- Accommodates rails 1-5/8", 2" and 2-3/8" in diameter
- Standard drill pattern to accommodate all Buyers racks
- Includes hardware for mounting to rail



Landscape Trailer Racks

BLOWER RACKS

Locking, Adjustable Backpack Blower Rack



Part No.	Description	Wt. (lb)	Cat.
LT24	Locking Adjustable Blower Rack	32.8	538(Y)

- Works with most blowers
- For tubes up to 5" diameter
- Includes keyed padlock
- Minimal assembly required
- Includes rubber anti-vibration skid pad and mounting hardware

Stihl® BR Series Blower Rack



Part No.	Description	Wt. (lb)	Cat.
LT22	Stihl® BR Series Blower Rack	6.5	538(Y)

- Specifically for STIHL® BR340 and BR420 blowers
- Secures with padlock
- Padlock and blower not included

Backpack Blower Rack



Part No.	Description	Wt. (lb)	Cat.
LT20	Backpack Blower Rack**	7	538(Y)

**Not for use with Stihl® BR blower

- Blowers mount and secure conveniently on hook with spring latch
- Includes rubber strap to secure equipment
- Secures with padlock
- Padlock and blower not included

GAS CANISTER RACKS

Locking Gas Canister Rack



Part No.	Description	Wt. (lb)	Cat.
LT32	Locking Gas Canister Rack	14.5	538(Y)

- Work with the following gas cans:
 - Blitz USA Inc. 5 and 6 gal
 - Midwest Can Co. Models 5600, 7600, & 8600
 - No-Spill Inc. Models 1058, 1450, 1456, & 1457
- Powder-coated steel
- Includes lock and steel pin to lock gas canister in place and mounting hardware

Gas Canister Rack



Part No.	Description	Wt. (lb)	Cat.
LT30	Gas Canister Rack	12	538(Y)

- Holds one 5-gal. or two 2-1/2-gal. rectangular polymer canisters (not included)
- Includes rubber strap to secure canister(s)

*Buyers Products is not authorized by nor affiliated with the manufacturer of Stihl®, Blitz USA, Midwest Can Co., or No-Spill Inc. products.

WATER COOLER RACKS

Universal Wire Form



5201007

5201009



Part No.	Description	Wt. (lb)	Cat.
5201007	Water Cooler Rack, 5 Gallon	3	520(Y)
5201009	Water Cooler Rack, 10 Gallon	7.8	520(Y)
5201008	Water Cooler Pipe Mount for 5 and 10 Gallon Water Coolers	-	520(Y)

- Wire formed steel construction
- Includes 1" tie down strap with buckle
- Includes mounting hardware
- Water cooler not included

Landscape Trailer



Part No.	Description	Wt. (lb)	Cat.
LT25	Water Cooler Rack	6.5	538(Y)

- Fits various sizes up to 5 Gallons
- Includes mounting hardware and adjustable straps
- Water cooler not included

Service Body



Part No.	Description	Wt. (lb)	Cat.
5201005	White Water Cooler Mount, Fits a Standard 3 to 5 Gallon Water Cooler	7.92	538(Y)

- Holds most 3 to 5 gallon coolers
- Includes mounting hardware and adjustable strap

HAND TOOL RACKS

Vertical



Part No.	Description	Wt. (lb)	Cat.
LT35	Vertical Hand Tool Rack	15	538(Y)

- Holds up to 6 straight handle tools (not included)
- Keeps tools organized and trailer floor clutter-free
- Includes rubber grommets to protect tools

Horizontal

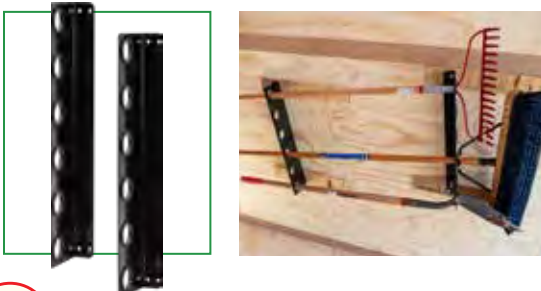

Part No.	Description	Wt. (lb)	Cat.
LT37	Horizontal Hand Tool Rack	9	538(Y)

- Holds up to 6 straight handle tools (not included)
- Keeps tools organized and trailer bed clutter-free
- Includes rubber grommets to protect tools



Traffic Cone Holders

TRAFFIC CONE HOLDERS

- Can fit up to ten 18 in. cones or five 28 in. cones
- Mounting plate is pre-drilled for easy installation on any flat surface (hardware not included)
- TCH10H and TCH10V sold in pairs

Vertical Mount



Part No.	Dimensions	Finish	Wt. (lb)	Cat.
TCH12V	12" Vertical Bracket Mount	Black Powder-Coat	8.4	520

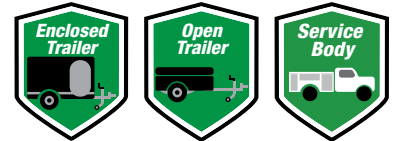
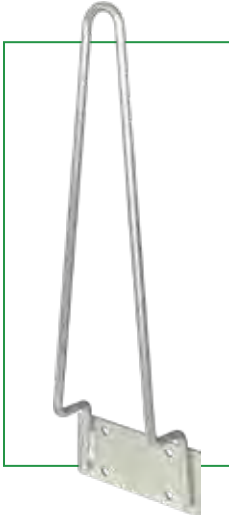

Part No.	Dimensions	Finish	Wt. (lb)	Cat.
TCH10V	22" Vertical Bracket Mount	Silver Powder-Coat (Zinc-Based)	2.5	520

Horizontal Mount

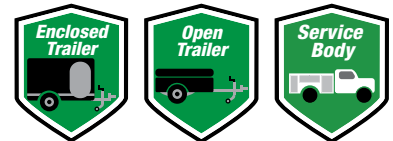

Part No.	Dimensions	Finish	Wt. (lb)	Cat.
TCH10H	18" Horizontal Bracket Mount	Silver Powder-Coat (Zinc-Based)	2.25	520

SHOVEL HOLDERS FOR TRUCKS

- HD spring mechanism secures shovel or other round handled tool
- Stainless steel or black powder-coated carbon steel
- Resists weather and corrosion for years of use

Carbon Steel

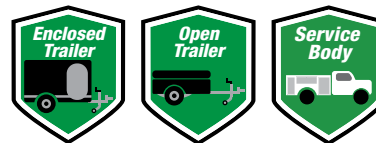

Part No.	Description	Finish	Wt. (lb)	Cat.
SH675	Shovel Holder	Black Powder Coat	2.75	520

Stainless Steel

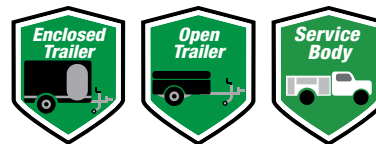

Part No.	Description	Finish	Wt. (lb)	Cat.
SH675SS	Shovel Holder	Silver	2.75	520



Stake Pocket

STAKE POCKET D-RINGS

- Fits common flush and outside stake pockets
- Provides convenient D-Ring tie down where needed
- Includes 1/2 in. hitch pin with cotter
- D-Rings not approved for overhead use

1/2 in. Forged D-Ring

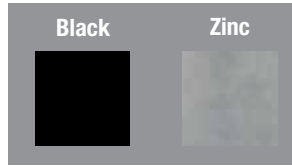
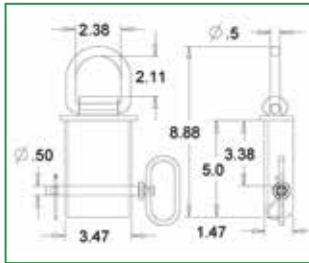

Part No.	Finish	Ring Diameter	I.D. Height	I.D. Width	Cat.
B38SP	Black Powder Coat	0.5"	2.11"	2.375"	524 (N)

3/8 in. Forged D-Ring

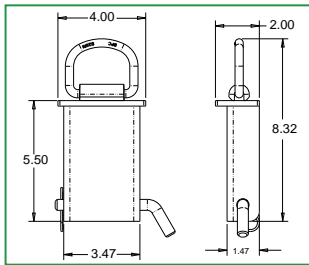

Part No.	Finish	Ring Diameter	I.D. Height	I.D. Width	Cat.
B28SP	Black Powder Coat	0.375"	2"	2.5"	524 (N)
B28SPZ	Zinc	0.375"	2"	2.5"	524 (N)

3/8 in. Forged D-Ring

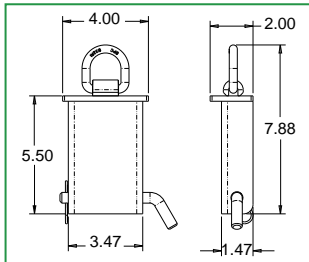

Part No.	Finish	Ring Diameter	I.D. Height	I.D. Width	Cat.
B32SP	Black Powder Coat	0.375"	1.5"	1.44"	524 (N)
B32SPZ	Zinc	0.375"	1.5"	1.44"	524 (N)

STAKE POCKET SPARE TIRE CARRIERS

- Holds tires with 19.5 in. rims or smaller
- Can be bolted or welded on, depending on your vehicle
- Oversized wing nut makes securing and unloading tires easy
- 14 Ga steel
- Corrosion-resistant black powder-coated finish



Part No.	Wt. (lb)	Cat.
5201010	8	520 (N)



- Gives tire extra clearance 6-1/2 inches out and 7-1/2 inches up from stake pockets
- Has three 5/8 in. holes and three 1/2 in. holes
- Fits most standard 3-1/2 in. and 3-3/4 in. stake pockets
- Durable steel with a black powder-coated finish for corrosion resistance



Part No.	Wt. (lb)	Cat.
5201012	9.49	520 (N)

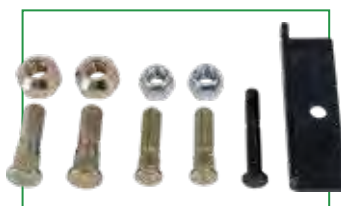

5201012 Hardware



Landscape Trailer Lights

SILICONE LED STRIP LIGHTS WITH 3M™ ADHESIVE BACK *Highest Lumens*

LIMITED LIFETIME WARRANTY
12 VOLTS
IP 68

Connection	Blunt Cut, Both Ends
Hardware Included	End Caps and Mounting Clips

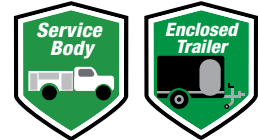
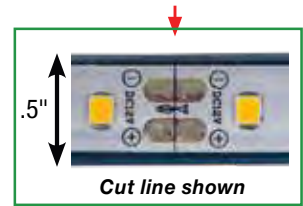

Clear Warm Strip Lights

Part No.	Color	Size	LED's	Amps	Lumens	Wt. (lbs.)	Cat.
5622029*	Clear, Warm	18"	27	0.45	486	0.31	562 (N)
5622840*	Clear, Warm	24"	36	0.60	648	0.35	562 (N)
5623856*	Clear, Warm	36"	54	0.90	972	0.40	562 (N)
5625276*	Clear, Warm	48"	72	1.20	1,296	0.44	562 (N)



Clear Cool Strip Lights

Part No.	Color	Size	LED's	Amps	Lumens	Wt. (lbs.)	Cat.
5622120*	Clear, Cool	18"	27	0.45	513	0.31	562 (N)
5622941*	Clear, Cool	24"	36	0.60	684	0.35	562 (N)
5623957*	Clear, Cool	36"	54	0.90	1,026	0.40	562 (N)
5625377*	Clear, Cool	48"	72	1.20	1,368	0.44	562 (N)



* **NEW** PRODUCTS

Products are Retail Packaged



LED STRIP LIGHTS WITH 3M™ ADHESIVE BACK

LIMITED
W
12
VOLTS
IP
67

Connection	Blunt Cut, Both Ends
Hardware Included	End Caps and Mounting Clips

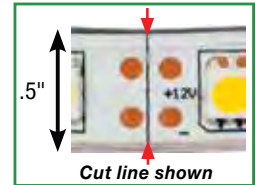

Clear Warm Strip Lights

Part No.	Color	Size	LED's	Amps	Lumens	Wt. (lbs.)	Cat.
5621827	Clear, Warm	18"	27	0.41	360	0.31	562 (N)
5622436	Clear, Warm	24"	36	0.54	470	0.35	562 (N)
5623654	Clear, Warm	36"	54	0.81	710	0.40	562 (N)
5624872	Clear, Warm	48"	72	1.12	940	0.44	562 (N)
5626090	Clear, Warm	60"	90	1.30	1,180	0.55	562 (N)
56296144	Clear, Warm	96"	144	2.00	2,160	0.88	562 (N)



Clear Cool Strip Lights

Part No.	Color	Size	LED's	Amps	Lumens	Wt. (lbs.)	Cat.
5621928	Clear, Cool	18"	27	0.41	360	0.31	562 (N)
5622537	Clear, Cool	24"	36	0.54	470	0.35	562 (N)
5623755	Clear, Cool	36"	54	0.81	710	0.40	562 (N)
5624973	Clear, Cool	48"	72	1.12	940	0.44	562 (N)
5626191	Clear, Cool	60"	90	1.30	1,175	0.55	562 (N)
56297145	Clear, Cool	96"	144	2.00	2,160	0.88	562 (N)
562109166	Clear, Cool	108"	165	3.00	2,400	1.12	562 (N)
562133202	Clear, Cool	132"	201	4.00	3,000	1.37	562 (N)



Landscape Trailer Lights

5" ROUND LED INTERIOR DOME LIGHTS



Number of LEDs	36
Lumens	2,200
Lead Length	8"
Connection	Blunt Cut



Part No.	ON/OFF Function	Color	Amp	Mounting	Wt. (lbs.)	Cat.
5625336	Remote Switch	Clear	1.5	Surface	0.39	562 (N)
5625337	Built-In Switch	Clear	1.5	Surface	0.39	562 (N)
5625338	Motion Sensor	Clear	1.5	Surface	0.39	562 (N)
5627036	Built-In Switch	Clear	1.5	Recessed	0.39	562 (N)
5627038	Motion Sensor	Clear	1.5	Recessed	0.39	562 (N)

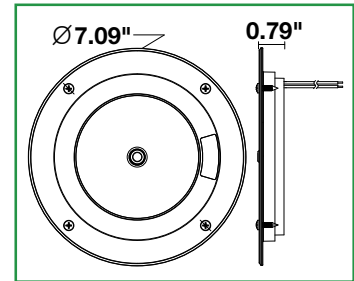
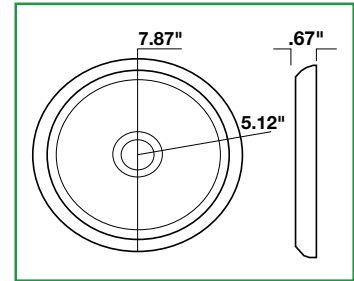

OVAL LED INTERIOR DOME LIGHTS



Number of LEDs	10
Lumens	80
Mounting	Grommet

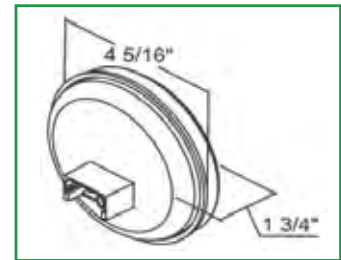
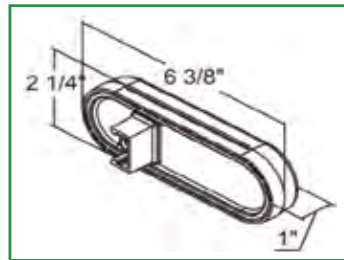

Part No.	Color	Amp	Connection	Std. Qty.	Wt. (lbs.)	Cat.
5626352	Clear	0.221	PL-3 Connection	10	0.37	562 (N)
5624352	Clear	0.221	PL-3 Connection	10	0.34	562 (N)

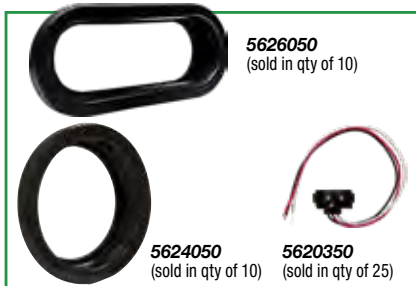

Accessories

Part No.	Description	Std. Qty.	Wt. (lbs.)	Cat.
5624050	Black Grommet for use with 5626352	10	0.15	562 (N)
5626050	Black Grommet for use with 5624352	10	0.15	562 (N)
5620350	3-Pin Right Angle Male Plug with Stripped Power Leads and #10 Ring on Ground	25	0.03	562 (N)

Bulk. Part number indicates single item only. 5626050 must be ordered in multiples of 10, and 5620350 must be ordered in multiples of 25.

WORK LIGHTS



6" LED Scene Light

5-YEAR W 12-24 VOLTS IP 67	Number of LEDs	52
	Lumens	2,296
	Lead Length	20"
	Mount / Base	45° Angled

Part No.	Type	Color	Amp	Connection	Wt. (lbs.)	Cat.
1492238*	Flood	Clear	1.54	Blunt Cut	0.65	562 (N)

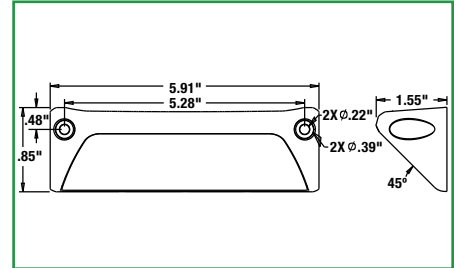
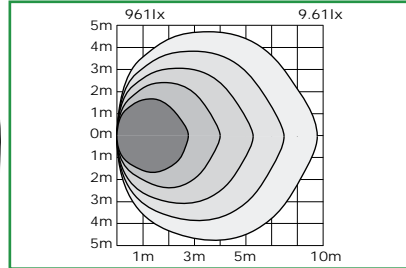

Angle Mounted 3" LED

5-YEAR W 12-24 VOLTS IP 67	Number of LEDs	3
	Lumens	1,260
	Lead Length	18"
	Mount / Base	Flat, Tubular and Angle



Part No.	Type	Color	Amp	Connection	Wt. (lbs.)	Cat.
1492139	Flood	Clear	0.34	Blunt Cut	0.32	562 (N)

Mounting options included: flat, tubular and angle

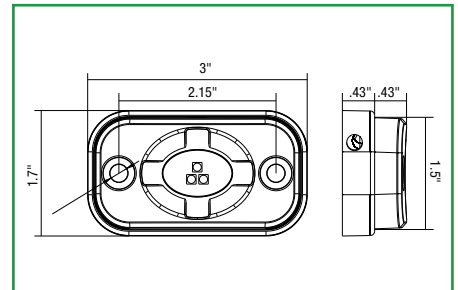
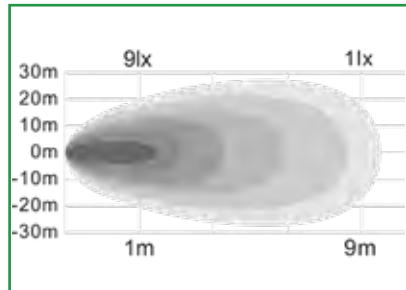

*** NEW PRODUCTS**



Products are Retail Packaged



E-Track

E-Track is a versatile, easy-to-install system to help organize your trailer to fit your needs. The tracks can be used with a variety of e-track accessories. Easily move items along track to reorganize as needed to satisfy your specific job needs.

Application



E-TRACK RAILS

- Convenient tie down points for securing cargo
- Ideal for wall or floor mounting

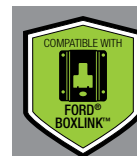

All E-Track accessories are compatible with the Ford® Boxlink™ System

Steel

- Corrosion resistant gunmetal grey powder-coated finish

1903050



Part No.	Length	Material	Finish	Pre-Drilled Holes	Cat.
1903050	10'	Steel	Powder Coated	Yes	520 (N)
1903055	5'	Steel	Powder Coated	Yes	520 (N)
1903052	2'	Steel	Powder Coated	Yes	520 (N)

Aluminum

1903110

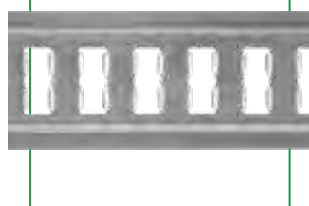

Part No.	Length	Material	Pre-Drilled Holes	Cat.
1903110	10'	Aluminum	No	520 (N)

E-TRACK STRAPS

- The perfect addition to E-track systems to secure cargo effortlessly
- 2 in. wide ratchet straps
- Easy to use, simply snaps into track providing a secure anchor

Yellow Ratchet Strap, Through Handle

- Zinc plated for corrosion resistance

01075

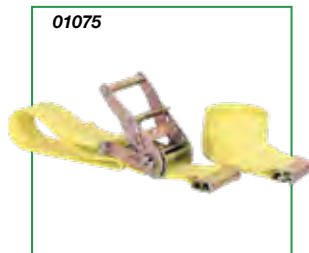

Part No.	Size	Hook Type	Pack Qty.	W.L.L. (lbs.)	Break Strength (lbs.)	Cat.
01075	2" x 12'	E-Track	1	1,467	4,400	520 (N)
01076	2" x 16'	E-Track	1	1,467	4,400	520 (N)
01077	2" x 20'	E-Track	1	1,467	4,400	520 (N)

Yellow Cambuckle Strap, Quick Thumb Release

- The cambuckle makes it easy to adjust tension and strap length to ensure a snug fit against your cargo

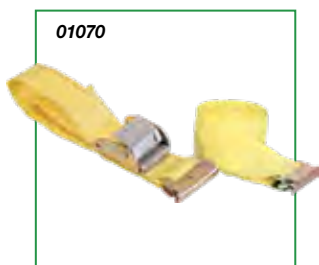

Part No.	Size	Hook Type	Pack Qty.	W.L.L. (lbs.)	Break Strength (lbs.)	Cat.
01070	2" x 12'	E-Track	1	915	2,745	520 (N)

10 Foot Retractable Black Strap, Rubber Grip Handle

- Strap easily retracts for tangle-free storage



Part No.	Size	Hook Type	Pack Qty.	W.L.L. (lbs.)	Break Strength (lbs.)	Cat.
5480011	2" x 10'	E-Track	1	1,000	3,000	520 (N)

E-TRACK ACCESSORIES

- Provide solutions for convenient and secure transportation of your cargo
- Ideal for wall mounting

Rope Ring Strap

- The D-ring provides an ideal anchor point for tie downs, ropes, or cords
- Zinc plated for corrosion resistance

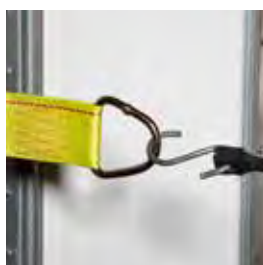
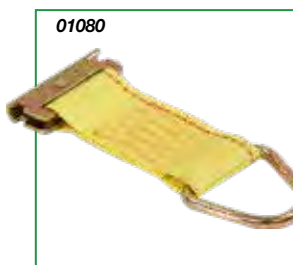

* E-Track sold separately

Part No.	Size	Hook Type	Pack Qty.	W.L.L. (lbs.)	Break Strength (lbs.)	Cat.
01080	6"	E-Track	1	1,000	3,000	520 (N)

Rope Ring

- Provides a secure and easy attachment point for tie downs
- Zinc plated for corrosion resistance
- Heavy duty steel construction

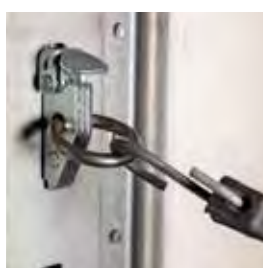

* E-Track sold separately

Part No.	Size (I.D.)	Hook Type	Pack Qty.	W.L.L. (lbs.)	Break Strength (lbs.)	Cat.
01090	1-5/16"	E-Track	1	2,000	6,000	520 (N)



E-Track

E-TRACK ACCESSORIES, CONTINUED

Square J-Hook

- The hook is 3/8 in. thick with an internal width of 2 in.
- Corrosion resistant white powder-coated finish
- Heavy duty steel construction

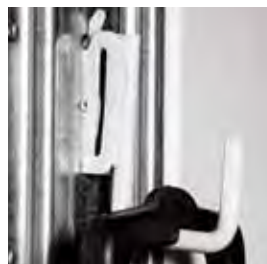
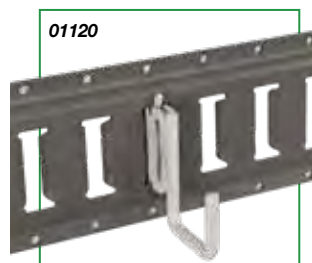

* E-Track sold separately

Part No.	Description	Cat.
01130	E-Track Square J-Hook	520 (N)

Curved J-Hook

- The hook is 1/2 in. thick with an internal width of 4-1/4 in.
- Corrosion resistant white powder-coated finish
- Heavy duty steel construction

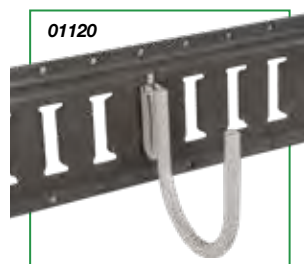

* E-Track sold separately

Part No.	Description	Cat.
01120	E-Track Curved J-Hook	520 (N)

Board Holder

- Holds 2 x 4 in. and 2 x 6 in. lumber to create wood partitions
- Bolt holes provided for additional security
- Corrosion resistant zinc plated steel construction

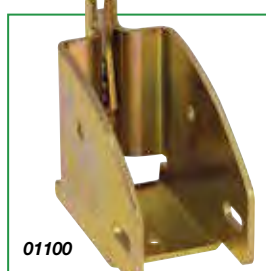

* E-Track sold separately

Part No.	Description	Cat.
01100	E-Track Board Holder	520 (N)

Spare Tire Carrier

- 7 in. Long, zinc plated steel
- Secures spare tire to wall

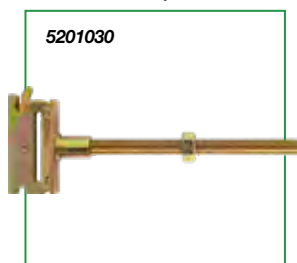

* E-Track sold separately

Part No.	Description	Cat.
5201030*	E-Track Spare Tire Carrier	520 (N)

SUPER TRACK

- Adjustable ring placement gives you maximum flexibility in locating tie down points
- Ideal for pickups, vans and enclosed trailers
- Eight anchor rings included
- Made of durable anodized extruded aluminum
- ST93 Includes four 46-1/2 in. anodized extruded aluminum tracks and eight rings

46.5 in. Aluminum

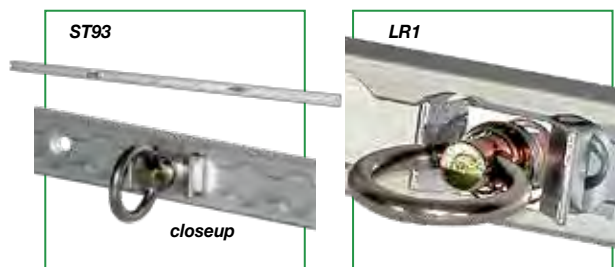

Part No.	Length	Material	W.L.L. (lbs.)	Break Strength (lbs.)	Cat.
ST93	46.5"	Aluminum	400	–	520 (N)
LR1	1" I.D.	Aluminum	1,000	3,000	520 (N)

DOT CONSPICUITY TAPE

- DOT approved
- ASTM D4956 - 93B Type V
- LS300C
- FP92
- NHTSA 49 CFT, Part 571, DOT-C2
- 5-Year Rating

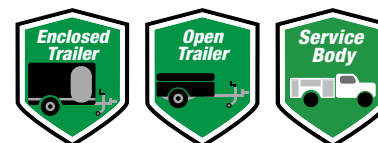
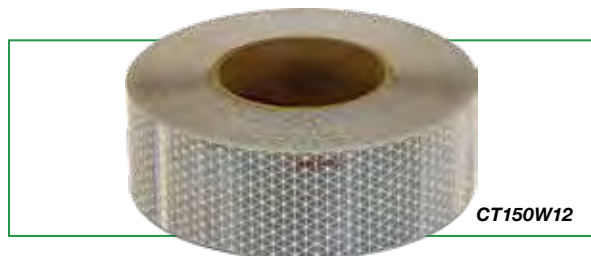
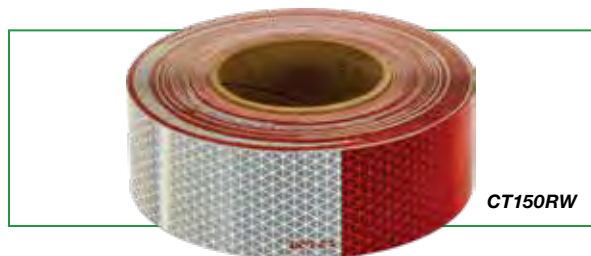

Part No.	Description	Std. Qty	Wt. (lbs.)	Cat.
CT150RW	DOT Conspicuity Tape, 150' Roll, 11" Red, 7" White	1	1.5	889 (N)
CT150W12	150' Roll, White, 12" Lengths	1	1.5	889 (N)

Stays on for up to five years with proper installation.



EZ GATE™ TAILGATE LIFT ASSIST Patented



*Also shown is 5201012 Stake Pocket Spare Tire Carrier



Part No.	Wt. (lb)	Cat.
 5201000	21	538(Y)

- Reduces lifting by 90%
- Reduces injuries and fatigue
- One kit works on gates up to 180 lbs.
- Simple installation
- No rattle spring insert
- Black-powder-coat finish
- Includes mounting hardware
- Works on open utility trailers with side rail height of 10"-14"
- 71" x 2-1/2" diameter tube

TRAILER RAMP COMPONENTS

Torsion Ramp Spring Accessory



Part No.	Description	Wt. (lb)	Cat.
3002879	Left Hand Torsion Ramp Spring for Heavy Duty Trailer Ramps	3.03	520 (N)
3002880	Right Hand Torsion Ramp Spring for Heavy Duty Trailer Ramps	3.03	520 (N)
3034278	Left Hand Torsion Ramp Spring for Trailer Ramps - Replaces Sure-Trac® ST9437L	0.63	520 (N)
3034279	Right Hand Torsion Ramp Spring for Trailer Ramps - Replaces Sure-Trac® ST9437R	0.63	520 (N)

- 23 in.-lbs. per degree rating
- 3-3/4" wide
- 1.88" I.D.
- .468" dia. bar
- For HD trailer ramps

Ramp Hinge Bracket Accessory



Part No.	Wt. (lb)	Cat.
RH4350	1.16	512 (N)

- Stamped from 1/2" steel plate
- Other thicknesses and configurations available by special order
- 4" L x 3" W
- 1.945" dia. hole
- Supports ramp spring mounting bars

STEEL

Black

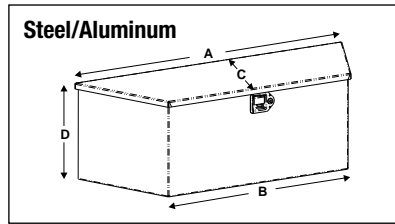

Part No.	Height (D)	Depth (C)	Width (A/B)	Wt. (lb)	Cat.
1701280	15	14.5	34/22.5	51	530 (Y)
1701281	12	13.25	26/14	33	530 (Y)
1701285	18.5	15	49/37	74	530 (Y)

- 14 gauge steel box with 12 gauge steel door
- Locking stainless steel paddle latch
- Stainless steel continuous hidden hinge
- Designed to mount to the front of A-frame style trailers

ALUMINUM

Diamond Tread



Part No.	Height (D)	Depth (C)	Width (A/B)	Wt. (lb)	Cat.
1701380	15	14.5	34/20.7	17.5	530 (Y)
1701385	18.5	15	49/37	28	530 (Y)

- .056 thick diamond tread aluminum
- Locking stainless steel paddle latch
- Aluminum continuous hidden hinge
- Designed to mount to the front of A-frame style trailers

POLY

Black

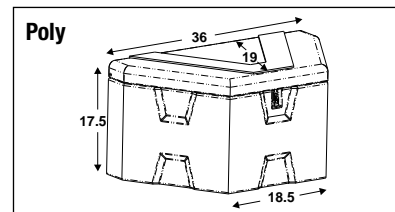

Part No.	Height	Depth	Width	Cubic ft.	Wt. (lb)	Cat.
1701680	18	19	36/18	5.34	21	530 (Y)

- Constructed of high-density polyethylene
- Designed to mount to the front of A-frame style trailers
- Corrosion and weather resistant stainless steel hasp and hinge made for use with combination lock or padlock (lock sold separately)

White



Part No.	Height	Depth	Width	Cubic ft.	Wt. (lb)	Cat.
1701679	18	19	36/18	5.34	21	530 (Y)



The Buyers family of manufacturing companies

Tracom

B **Boomerang**
RUBBER, INC.

R **Romotech**
Rotational Molding Technologies, Inc.

P **PROGRESSIVE**
POWDER COATING, INC.



BuyersProducts.com

Buyers
PRODUCTS COMPANY 

SnowDogg
by **Buyers** 

SaltDogg
by **Buyers** 

ScoopDogg
by **Buyers** 

DumperDogg
by **Buyers** 

LITLANDSCAPE_C